

# UNIQUE FIRE INDUSTRY

## PRODUCT CATALOGUE



### ADDRESS

No. 9, Jalan Anggerik Mokara 31/55,  
Kota Kemuning, Seksyen 31, 40460,  
Shah Alam, Selangor, Malaysia

### CONTACT

T: +603 5131 1226

E: [contactus@uniquefire.com](mailto:contactus@uniquefire.com)

W: [www.uniquefire.com](http://www.uniquefire.com)



SCAN ME



# UNIQUE FIRE HOLDINGS MILESTONE

1997 - 2013

## UNIQUE FIRE INDUSTRY

Assembled our own brand of fire hoses (2000).  
Changed our name from UBE to Unique Fire Industry Sdn Bhd ("UFI") and registered the trademarks for Commander and Yama brands fire hoses (2003)



2016

## UL APPROVAL

UFI obtained our first international approval, UL certification for our Unique227 brand of HFC fire suppression system

2018

## SGP CERT

UFI obtained SGP for our HFC fire suppression systems - Unique227 brand from TNB.  
UDI commenced business of distributing custom graphics designed fire extinguishers.

2021

## FM APPROVAL

UFI received first FM approvals certification for our Unique227 and Unique5112 brand of fire suppression system.



NOW

## ACE MARKET

As of 2022, we are proudly listed on the ACE Market of Bursa Malaysia.

# FIRE HYDRANT/WET & DRY RISER SYSTEM

The main components of a fire hydrant system are fire hoses, fire hydrants, valves and breeching inlets. A fire hydrant is an above-ground piece of equipment that gives access to a water supply that may not be pressurised. The system can either be a dry riser system or a wet riser system.

In a dry riser system, the water needed to fight a fire in an emergency is charged by the fire brigade. The breeching inlets are usually housed in cabinets installed in each floor of a building. The wet riser system holds pressurised water which is connected to the water mains and the water is kept in check by means of valves. The breeching inlets for this system are also housed in inlet cabinets that indicate the type of riser system in use.

SCAN ME



## YAMA Fire Hose



TECHNICAL DATA			
Part No.	FH-13W-40	FH-13W-65	FH-10W-65
Size	40mm	65mm	65mm
Working Pressure	13 bar		10 bar
Burst Pressure	30 bar		25 bar
Test Pressure	20 bar		16 bar
Length	30m		
Type	Type 1, Light Weight Fire Hose		
Material	Tough Woven Polyester Fabric		
Finishing	White		

## COMMANDER Fire Hose



TECHNICAL DATA		
Part No.	FH-16W-65	FH-16R-65
Size	65mm	65mm
Working Pressure	16 bar	
Burst Pressure	32 bar	
Length	30m	
Type	Type 1, Light Weight Fire Hose	
Material	Tough Woven Polyester Fabric	
Test Pressure	25 bar	25 bar
Finishing	White	Red

UNIQUE FIRE INDUSTRY SDN BHD Co. No. 418731-U

Address:

No. 9, Jalan Anggerik Mokara 31/55, Kota Kemuning, Seksyen 31, 40460, Shah Alam, Selangor, Malaysia

Contact:

Tel : +603 5131 1226

E-mail : [contactus@uniquefire.com](mailto:contactus@uniquefire.com)

Website: [www.uniquefire.com](http://www.uniquefire.com)

SCAN ME





## Breeching Inlet



TECHNICAL DATA		
Part No.	DRU-2W	WRU-4W
Model	2 Way	4 Way
Dimension	316mm(L) x 219mm(W) x 235mm(H)	382mm(L) x 280mm(W) x 270mm(H)
Outlet Size	Flange (4") 100mm Table E	Flange (6") 150mm Table E
Inlet Size	BS 336 Male Instantaneous	
Working Pressure	10 bar	
Test Pressure	20 bar	
Material	Cast Iron (Body)	
	Copper Alloy (Male Instantaneous)	
Finishing	Red	

## E-TYPE LANDING VALVE / PRESSURE REGULATING VALVE



TECHNICAL DATA		
Part No.	WRU-EPRV	WRU-EPRV-F
Type	Screw Type (Thread)	Flange Type
Size	Ø65mm (2 1/2")	
Test Pressure	30 bar	
Max. Inlet Pressure	20 bar	
Factory Pre-Set Pressure	7 bar	
Inlet Size	65mm BSP Thread	
Outlet Size	BS 336 Female Instantaneous	
Material	Copper Alloy (Body)	
	Cast Iron (Handwheel)	
Finishing	Red or Yellow	
Features	Suitable to use for inlet pressure up to 20 bar	
	Setting for reduced outlet static pressure from 5 to 8 bar	
	When inlet pressure range from 7 to 20 bar, outlet pressure will remain constant	

All specifications and information indicated in this catalogue are subjected to change without prior notice.

UNIQUE FIRE INDUSTRY SDN BHD Co. No. 418731-U

Address:

No. 9, Jalan Anggerik Mokara 31/55, Kota Kemuning, Seksyen 31, 40460, Shah Alam, Selangor, Malaysia

Contact :

Tel : +603 5131 1226

E-mail : [contactus@uniquefire.com](mailto:contactus@uniquefire.com)

Website: [www.uniquefire.com](http://www.uniquefire.com)

SCAN ME



## ZYfire Rubber Hose



CONFIRMING TO  
BS: 6391 TYPE 3

### Specifications

Reinforcement : Synthetic Yarn  
Cover and Tube : Nitrile/TPR Blend tube, heavy rib with higher abrasion resistance  
Application : Industrial fire fighting, fire hose for brigade, water discharge

TECHNICAL DATA		
Part No.	FH-14ZY-65	FH-14ZY-40
Size	65mm	40mm
Material	Nitrile Rubber	
Length	30m	
Type	BS6391-Type 3	
Working Pressure	14bar (200psi)	
Minimum Burst Pressure	42bar (600psi)	
Number of Layers	<b>Three (3):</b> Tuber : Nitrile / TPR Blend etc Reinforcement Jacket : Polyester or Nylon Cover : Nitrile / TPR Blend etc	

## Hose Cradle

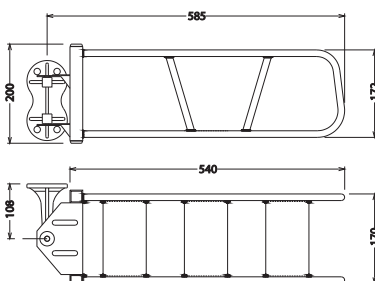

TECHNICAL DATA	
Part No.	WRU-HC
Material	Mild Steel (Body) Aluminium (Hinge)
Support Weight	38 kg max.
Finishing	Red Polyester Electrostatic Powder Coating

UNIQUE FIRE INDUSTRY SDN BHD Co. No. 418731-U

Address:

No. 9, Jalan Anggerik Mokara 31/55, Kota Kemuning, Seksyen 31, 40460, Shah Alam, Selangor, Malaysia

Contact :

Tel : +603 5131 1226

E-mail : [contactus@uniquefire.com](mailto:contactus@uniquefire.com)

Website: [www.uniquefire.com](http://www.uniquefire.com)

SCAN ME



## Diffuser Nozzle

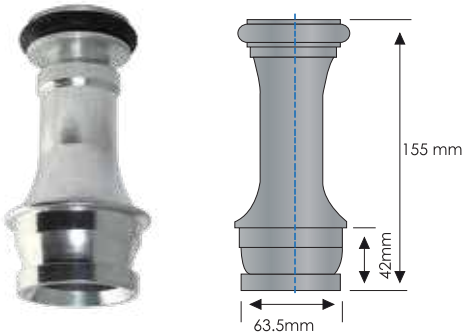

TECHNICAL DATA	
Part No.	FN
Material	Light Alloy/ Brass/ Bronze
Inlet	Ø65mm (male)
Connection	Instantaneous
Flow Rate @ 65 psi (4.4 bar)	500 L/min (Jet), 590 L/min (Spray)
Throw Range @ 65 psi (4.4 bar)	26m (Jet), 15m (Spray)
Test Pressure	Maximum 18 Bar

## Branch Pipe with Nozzle



TECHNICAL DATA	
Part No.	WRU-BPN
Material	Light Alloy/ Brass/ Bronze
Inlet	Ø65mm (male)
Connection	Instantaneous
Flow Rate @ 65 psi (4.4 bar)	510 L/min (19mm dia.)
Throw Range @ 65 psi (4.4 bar)	22m (19mm dia.)

## Instantaneous Coupling

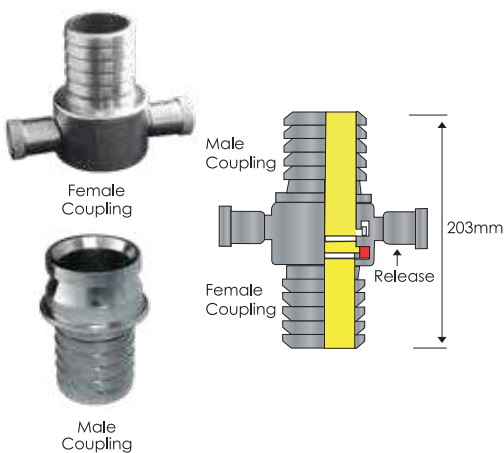

TECHNICAL DATA	
Part No.	FHC-F40, FHC-M40 FHC-F65, FHC-M65
Material	Light Alloy
Inlet	Ø40mm Ø65mm
Connection	Instantaneous

All specifications and information indicated in this catalogue are subjected to change without prior notice.

UNIQUE FIRE INDUSTRY SDN BHD Co. No. 418731-U

Address:

No. 9, Jalan Anggerik Mokara 31/55, Kota Kemuning, Seksyen 31, 40460, Shah Alam, Selangor, Malaysia

Contact :

Tel : +603 5131 1226

E-mail : [contactus@uniquefire.com](mailto:contactus@uniquefire.com)

Website: [www.uniquefire.com](http://www.uniquefire.com)

SCAN ME



## 2-Way Fire Hydrant with Landing Valve

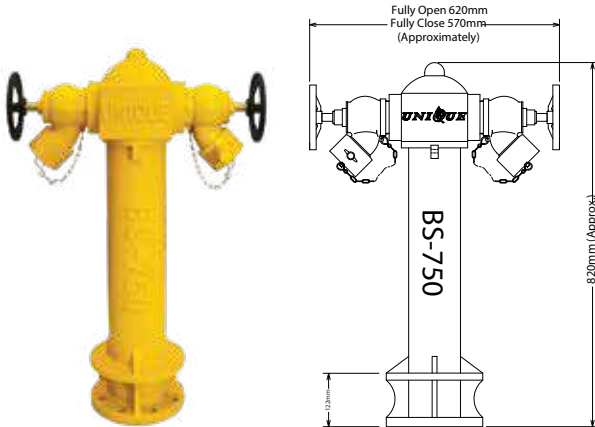

TECHNICAL DATA	
Part No.	HYU-2WHV
Working Pressure	15 bar
Test Pressure	20 bar
Flange Inlet Size	(4") 100mm Table E BS 10 Flange
Outlet	BS336 Instantaneous (Female)
Material (Body)	Ductile Iron
Material (Valve)	Copper Alloy
Finishing	Yellow or Red

## Plain End Pillar Hydrant

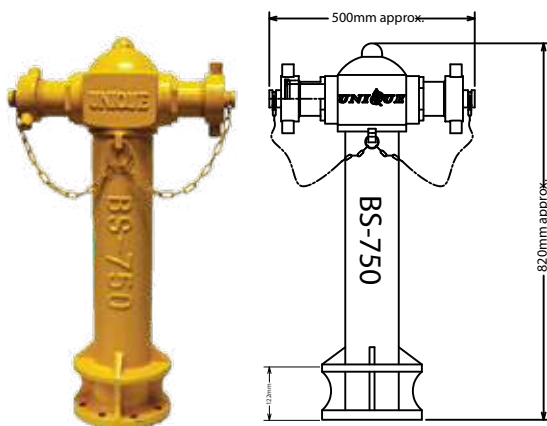

TECHNICAL DATA	
Part No.	HYU-2WHPE
Working Pressure	15 bar
Test Pressure	20 bar
Flange Inlet Size	(4") 100mm Table E BS 10 Flange
Outlet	BS 336 Male Threaded
Material (Body)	Ductile Iron
Material (Plain End)	Cast Iron
Finishing	Yellow or Red
Outlet Size	5-1/3" Thread Per Inch

All specifications and information indicated in this catalogue are subjected to change without prior notice.

UNIQUE FIRE INDUSTRY SDN BHD Co. No. 418731-U

Address:

No. 9, Jalan Anggerik Mokara 31/55, Kota Kemuning, Seksyen 31, 40460, Shah Alam, Selangor, Malaysia

Contact :

Tel : +603 5131 1226

E-mail : [contactus@uniquefire.com](mailto:contactus@uniquefire.com)

Website: [www.uniquefire.com](http://www.uniquefire.com)

SCAN ME





# Fire Hydrant System / Wet & Dry Riser

Fire Hydrant Landing Valve



TECHNICAL DATA		
Part No.	DRU-LV	DRU-LV-F
Model	Screw Type (Thread)	Flange Type
Size	Ø65mm (2 1/2")	
Working Pressure	7 bar	
Test Pressure	30 bar	
Minimum Flow Rate	8.5 Litre / second @ 4.5 Bar	
Inlet Size	65mm BSP Thread	
Outlet Size	BS 336 Female Instantaneous	
Material	Copper Alloy (Body)	
	Cast Iron (Handwheel)	
Finishing	Red or Yellow	

Breeching Inlet Cabinet



TECHNICAL DATA		
Part No.	CAB-2W	CAB-4W
Model	2 Way Breeching Inlet	4 Way Breeching Inlet
Size (mm)	595(W)x395(H)x295(D)	555(W)x565(H)x300(D)
Material	Mild Steel	
Thickness	0.9mm	
Outlet	(4") Flange 100mm Table E	(6") Flange 150mm Table E
Finishing	Epoxy Powder Red	
Design	BS 5041: Part 5	

Hydrant Hose Cabinet



TECHNICAL DATA		
Part No.	CAB-HCL	CAB-HC
Model	With Legs	Without Legs
Size (mm)	560(W)x1165(H)x300(D)	560(W)x630(H)x300(D)
Material	Mild Steel	
Finishing	Epoxy Powder Coating	

UNIQUE FIRE INDUSTRY SDN BHD Co. No. 418731-U

Address:

No. 9, Jalan Anggerik Mokara 31/55, Kota Kemuning, Seksyen 31, 40460, Shah Alam, Selangor, Malaysia

Contact :

Tel : +603 5131 1226

E-mail : [contactus@uniquefire.com](mailto:contactus@uniquefire.com)

Website: [www.uniquefire.com](http://www.uniquefire.com)

SCAN ME

